

Booster Pump Systems Horizontal Type - Press Control

PP - PS Series

Applications

- Water supply for small size villas and apartments
- General housings and small commercial buildings where pressurization is necessary
- Mansions, Motels and small size buildings
- Small size sprinkling system & water treatment facility

Specifications

Maximum Discharge flow	7 m ³ /hr		
Total Pump Head	37 m		
Maximum Ambient Temperature	+40°C		
Working Temperature Range	-15°C ~ +80 C		
Power Rating: Input / Output	220V 50Hz Ø 3 220/415V 50Hz		
Pump Material	Casing	Impeller	Shaft
	SS 304		
Sealing Device	Mechanical Seal		

Features

- One body pr. control which maintains perfect constant pressure
- Excellent energy saving effect
- Low water level auto detection & various pump protection functions
- Low noise & vibration by press control
- Pump is completely made of SS304, always supplying clean water
- Revolution speed control & avoidance of water hammer by tank
- Overload protection & restart after electricity shut-off

Outline Diagrams

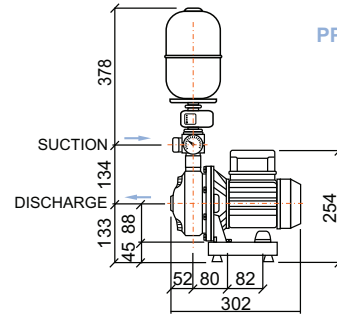
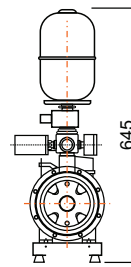

PP50-PS Series

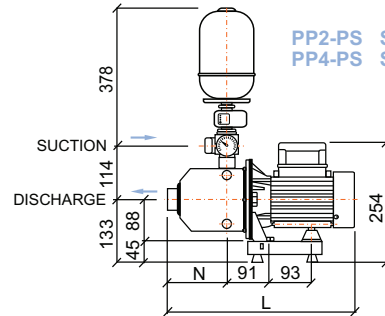
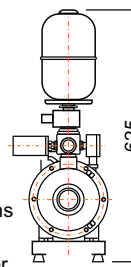

PP2-PS Series
PP4-PS Series

Performance Data & Dimensions

Model		Power		Flow (m ³ /hr)	Head (m)	Diameter (mm)		Dimensions (mm)		Weight Kg.
Pressure Sensor	Press Control	KW	HP			Suction	Discharge	N	L	
PP50PS	PP50PS	0.37	0.50	1.2 ~ 4.8	12.5 ~ 9	32(G1¼")	25(G1")	-	-	8
PP2-20PS	PP2-20PS	0.37	0.50	0.5 ~ 3.5	18 ~ 11	25(G1")	25(G1")	76	353	9
PP2-30PS	PP2-30PS	0.55	0.75	0.5 ~ 3.5	26 ~ 16	25(G1")	25(G1")	130	407	10
PP2-40PS	PP2-40PS	0.55	0.75	0.5 ~ 3.5	35 ~ 21	25(G1")	25(G1")	130	407	11
PP2-50PS	PP2-50PS	0.55	0.75	0.5 ~ 3.5	44 ~ 26	25(G1")	25(G1")	130	407	12
PP2-60PS	PP2-60PS	0.75	1.00	0.5 ~ 3.5	53 ~ 30	25(G1")	25(G1")	130	407	13
PP4-20PS	PP4-20PS	0.55	0.75	1.0 ~ 7.0	18 ~ 11	32(G1¼")	25(G1")	76	353	9
PP4-30PS	PP4-30PS	0.75	1.00	1.0 ~ 7.0	27 ~ 17.5	32(G1¼")	25(G1")	130	407	10
PP4-40PS	PP4-40PS	0.75	1.00	1.0 ~ 7.0	36 ~ 23	32(G1¼")	25(G1")	130	407	11

Performance Curves

Water test temp: °20 C Performance Limits: ISO2548td Class C pumps

